

LM3578 PWM PCB Drill speed controller

Author Rajkumar Sharma

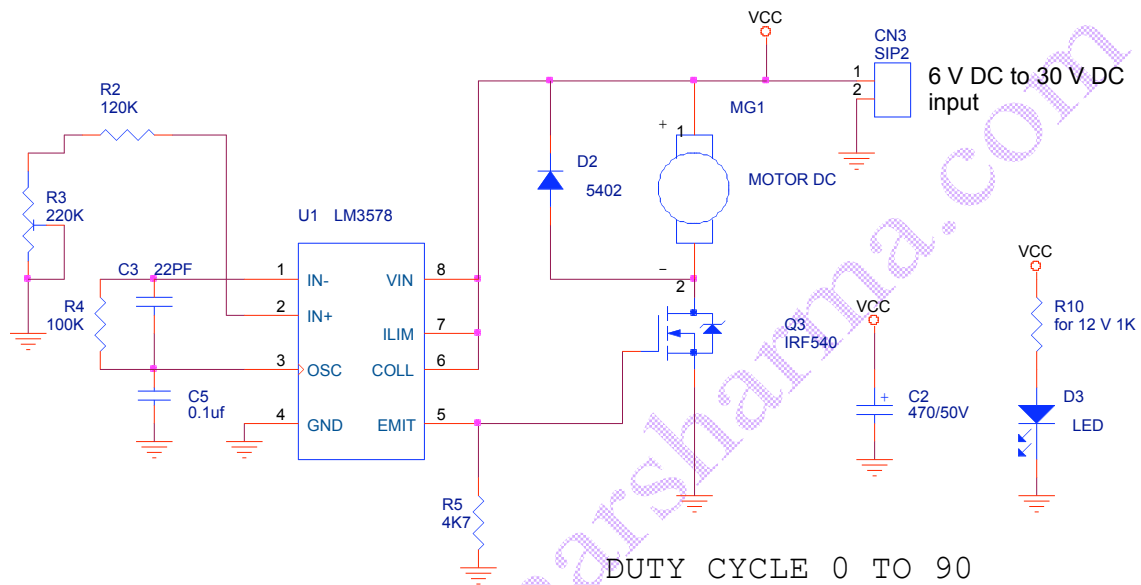

This simple project is use to control the DC motor speed based on 555 timer

- This circuit is based on PWM
- R3 is to control the speed of Drill
- IRF540 is N channel Mosfet CN2 is goes to DC motor
- CN3 is DC supply in 6V DC to 30V DC depend on drill motor Voltages
- D3 is LED indication for supply