

Stepper Motor Controller

Author Rajkumar Sharma

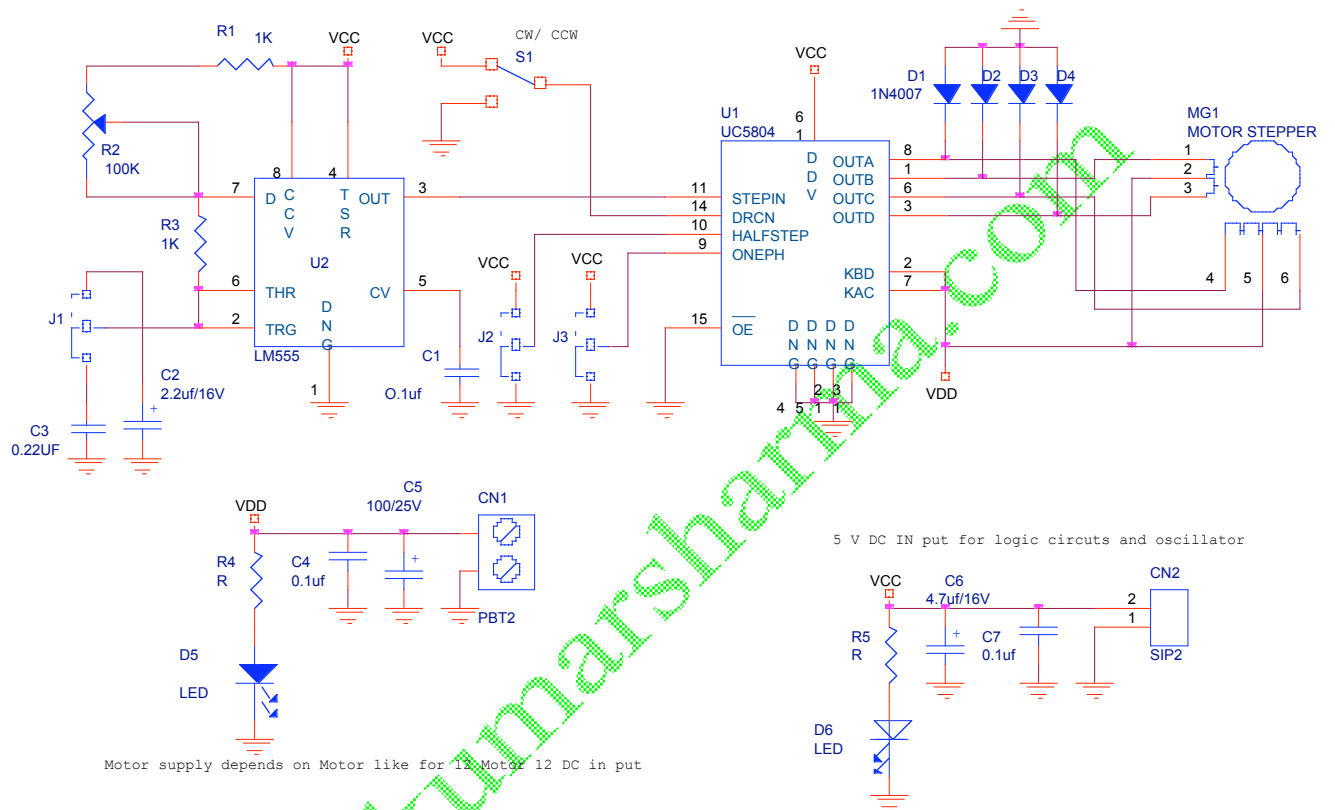

UCN5804 is Stepper Motor driver IC this IC can drive up to 1.5 Amp Motors, 555 is oscillator. J1 is to set the speed range and R2 pot is to control the speed SW1 is for direction control forward or reverse this circuit will take two supply one is for motor and second supply is 5V dc for logics.